



Technical Manual for the Fire Alarm Call Point - SM87 PBL

Please note that every care has been taken to ensure the accuracy of our technical manual. We do not, however, accept responsibility for damage, loss or expense resulting from any error or omission. We reserve the right to make alterations in line with technical advances and industry standards.

1. INTRODUCTION

These fire alarm call point units have been designed for use in harsh environmental conditions.

2. INSTALLATION

General

When installing and operating explosion-protected electrical equipment, requirements for selection, installation and operation should be referred to eg. IEC 60079-14 worldwide and the 'National Electrical Code' in North America. Additional national and/or local requirements may apply.

Ensure that all nuts, bolts and fixings are secure.

Ensure that only the correct UL listed stopping plugs are used to blank off unused gland entry points and that the NEMA/IP rating of the unit is maintained.

The SM87PBL is mounted via 4 x Ø 0.354" (9mm) fixing holes in the base.

The fixing holes have been designed to accept an M8 caphead screw or bolt. MEDC recommend the use of stainless steel screws.

Cable Termination

Unscrew and remove the 4 off screws holding the cover assembly to the base. Keep in a safe, accessible location.

Twist the cover assembly gently clockwise and anti-clockwise, whilst pulling it away from the base. Remove to gain access to the interior of the base.

Cable termination should be in accordance with specifications applying to the application. MEDC recommend that all cables and cores should be fully identified.

Ensure that only correct UL Listed cable glands are used and that the assembly is shrouded and correctly earthed.

All cable glands should be of an equivalent NEMA/IP rating to that of the call point and integrated with the unit such that this rating is maintained.

The internal earth terminal (where fitted), must be used for the equipment grounding connection and the external terminal is for a supplementary bonding connection where local codes or authorities permit or require such a connection.

Once termination is complete, carefully push the cover assembly back onto the base, avoiding damage to the mating surfaces. Replace the 4 off screws into the holes in the cover assembly and tighten evenly, to ensure maintenance of the required gap between the cover & base.

3. OPERATION

The call point is operated by lifting the flap on the front of the unit, then depressing the stainless steel actuator underneath. The actuator remains latched in an operated position. To reset the call point, the key (provided with the unit) is inserted into the slot provided in the actuator front face and pulled back to the initial position. The key is then removed and the flap lowered.

GENERAL ARRANGEMENT

ALL DIMENSIONS IN INCHES AND MILLIMETERS

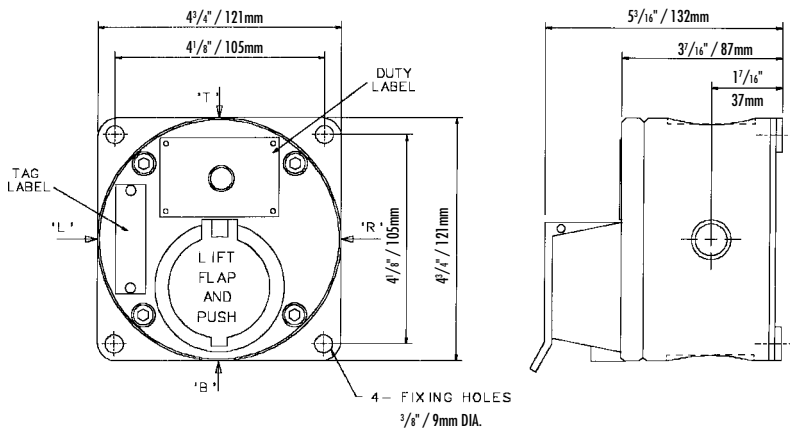

4. MAINTENANCE

During the working life of the call point, little or no maintenance is required. However, if abnormal or unusual environmental conditions occur due to plant damage or accident etc., then visual inspection is recommended.

If a fault should occur, it is recommended that the unit be returned to MEDC for repair. All parts are replaceable.

If you have acquired a significant quantity of units, it is recommended that spares are also made available. Please discuss your requirements with the Technical Sales Engineers at MEDC.

5. WARNING STATEMENTS

- i) To reduce the risk of ignition of hazardous atmospheres, disconnect the equipment from the supply circuit before opening. Keep assembly tightly closed when in operation
- ii) To reduce the risk of ignition of hazardous atmospheres, conduit runs must have a sealing fitting connection within 18 inches of the enclosure

Avertissements

- i) Afin de réduire le risque d'allumage et d'incendie dans des atmosphères dangereuses, déconnectez l'équipement du circuit d'alimentation avant de procéder à son ouverture. Maintenez l'appareil fermé hermétiquement lors de son utilisation
- ii) Afin de réduire le risque d'allumage et d'incendie dans des atmosphères dangereuses, les courses de conduits doivent être dotées d'un raccord d'étanchéité situé à 18 pouces ou moins du boîtier

6. CERTIFICATION/APPROVALS

Please refer to marking on the unit for specific approval details

- UL listed for use in Class 1, Division 1, Groups C & D
USA (USL) Class 1, Zone 1, Groups IIA & IIB
- UL Standards UL1203 & UL864
- Suitable for hazardous location fire-alarm applications

7. CERTIFIED TEMPERATURE

-55°C to +55°C

-67°F to +131°F

8. FUNCTIONAL SAFETY

Introduction

The SM87PB Call Point has been designed for use in potentially explosive atmospheres and harsh environmental conditions. The marine grade alloy or stainless enclosures are for use offshore or onshore, where light weight combined with corrosion resistance and strength is required.

The function of the call point is to raise an alarm manually once verification of a fire or emergency condition exists, by pushing the button.

The safety function of the SM87PB Call Point is to raise the alarm when the Button is pressed.

Under No fault (Normal) Operating conditions the SM87PB Push Button Unit will raise the alarm upon operating the switch via pushing the button.

Under fault conditions the failure mode of the Push Buttons is a failure to raise the alarm. For the failure rate associated with this failure mode please refer to the table below.

Assessment of Functional Safety

The SM87PB Call Point is intended for use in a safety system conforming to the requirements of IEC61508.

UL has conducted a Failure Modes Effect and Diagnostic Analysis (FMEDA) of the SM87PB Push Button unit against the requirements of IEC61508-2 using a proof test interval of 8760hrs.

The results are shown on the next page and are based on Route 1_H
The Call Point is classed as a Type A device.

SM87PB Pushbutton			
Safety Function of SM87PB Push Button: <i>'To raise the alarm upon pushing the button'</i>			
Architectural constraints:	Type A HFT=0 SFF= 79.7%	Proof Test Interval =8760Hrs MTTR = 8 Hrs	SIL2
Random hardware failures:	$\lambda_{DD} = 0$ $\lambda_{DU} = 3.43E-08$	$\lambda_{SD} = 0$ $\lambda_{SU} = 1.34E-07$	
Probability of failure on demand:	$PFD_{AVG} = 1.50E-04$ (Low Demand Mode)		SIL3
Probability of Dangerous failure on safety function:	$PFH = 3.43E-08$ (High Demand Mode)		SIL3
Hardware safety integrity compliance ^[1]	Route 1 _H		
Systematic safety integrity compliance	Route 1 _S		
Systematic Capability	SC2		
Overall SIL-capability achieved	SIL 2 (Low Demand)* SIL 2 (High Demand)* *Limited to SIL 2 due to SFF value		

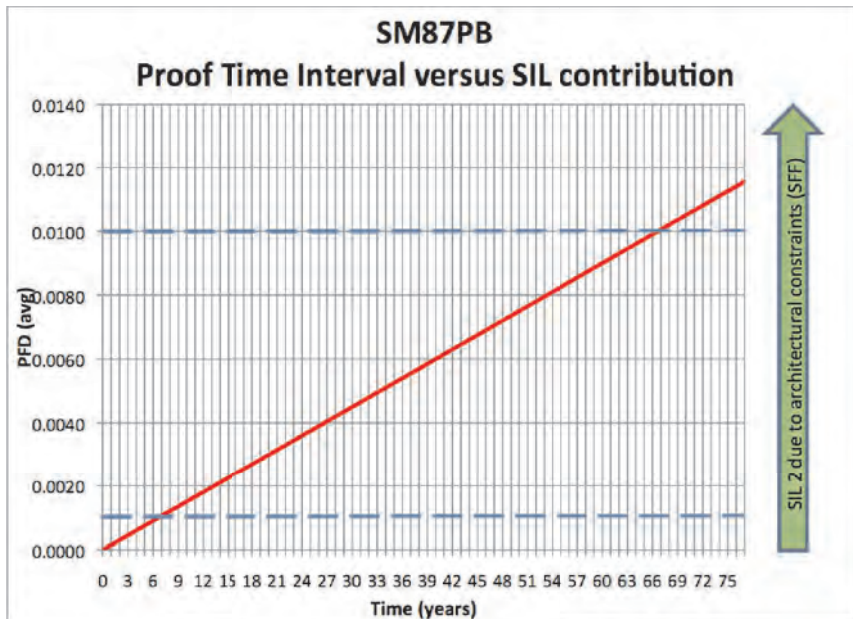

Conditions of Safe use

The following conditions apply to the installation, operation and maintenance of the assessed equipment. Failure to observe these may compromise the safety integrity of the assessed equipment:

1. The user shall comply with the requirements given in the manufacturer's user documentation (This Safety Manual and Technical manual) in regard to all relevant functional safety aspects such as application of use, installation, operation, maintenance, proof tests, maximum ratings, environmental conditions, repair, etc;
2. Selection of this equipment for use in safety functions and the installation, configuration, overall validation, maintenance and repair shall only be carried out by competent personnel, observing all the manufacturer's conditions and recommendations in the user documentation.
3. **All information associated with any field failures of this product should be collected under a dependability management process (e.g., IEC 60300-3-2) and reported to the manufacturer.**
4. The unit should be tested at regular intervals to identify any malfunctions; in accordance with this safety manual.

MEDC Ltd, Unit B, Sutton Parkway, Oddicroft Lane, Sutton in Ashfield, United Kingdom NG17 5FB
Tel: +44 (0)1623 444444 Fax: +44 (0)1623 444531
Email: MEDCSales@Eaton.com MEDCOrders@Eaton.com
Web: www.medc.com

MEDC Stock No:
TM103-ISS.C