

DO NOT SCALE

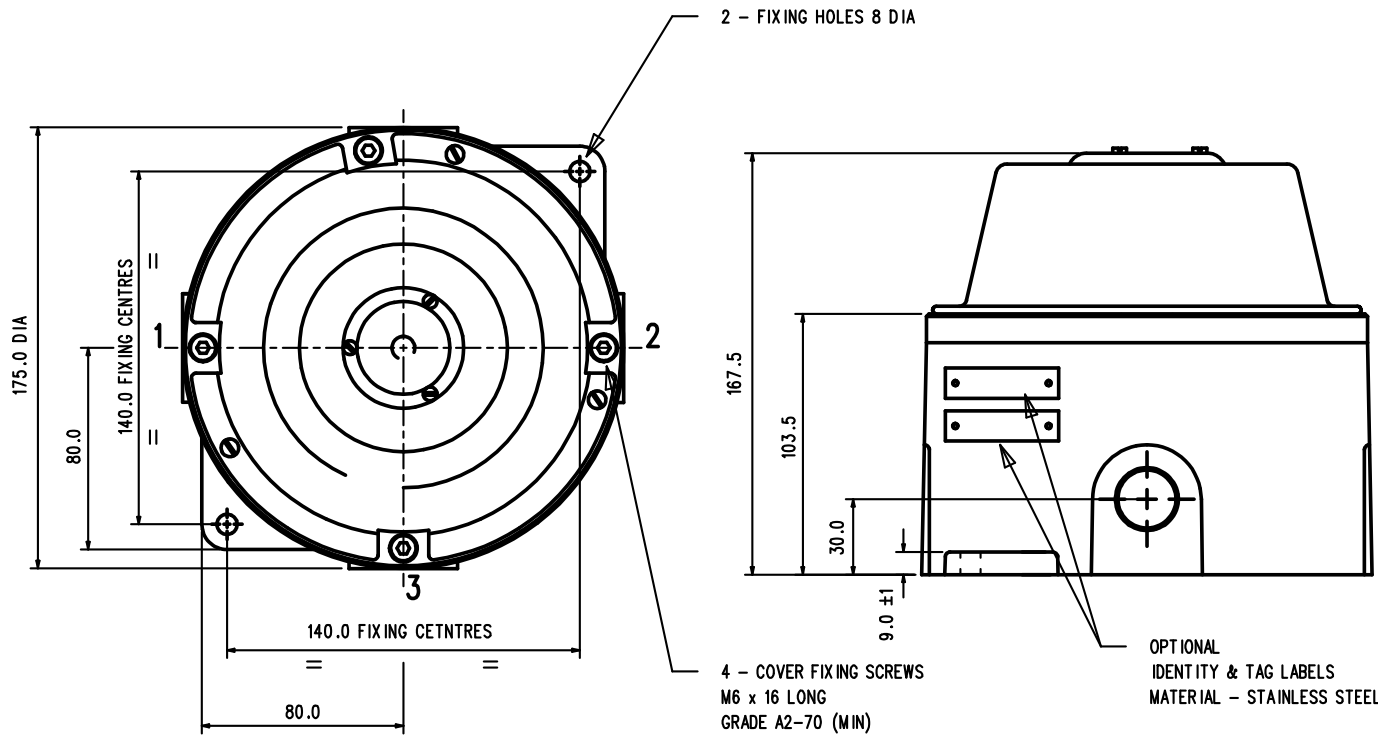

- 1/ TYPE DB1
- 2/ CERTIFICATION No. Baseefa02ATEX0207
II 2G EExd IIB T3 (T.Amb -20°C to +55°C).
- 3/ WEIGHT 3.5 ±0.2Kg (ALUMINIUM) & 8.3 ±0.2Kg (S.STEEL)
- 4/ MATERIAL - BODY & LID - ALUMINIUM GRADE LM25TF TO BS1490:1988
OR
STAINLESS STEEL GRADE 316/ANC 4B TO BS3146:1975
RE-ENTRANT HORN - POLYCARBONATE
- 5/ IDENTITY/TAG LABELS LETTER SIZE 5mm MAX
- 6/ TERMINALS SUITABLE FOR UP TO 2.5mm SQ CABLE
- 7/ CABLE ENTRIES AVAILABLE AT '1' '2' '3'
- 8/ HYLOMAR PL32 SEALANT APPLIED TO ALL CERTIFIED
BLANKING PLUGS

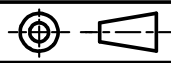

MEDC Ltd, Colliery Road, Pinxton,
Nottingham NG16 6JF, U.K.
Tel: +44 (0)1773 864100
fax: +44 (0)1773 582800
e-mail: info@medc.com
web: www.medc.com

DESIGNERS & MANUFACTURERS
OF ELECTRICAL & ELECTRONIC
EQUIPMENT & SYSTEMS FOR
HAZARDOUS AREAS

ISSUES	C.02-01-04 SO	ALL DIMENSIONS ARE IN MILLIMETRES UNLESS OTHERWISE STATED	THIS DRAWING IS CONFIDENTIAL AND IS THE PROPERTY OF MEDC AND MUST NOT BE REPRODUCED EITHER WHOLLY OR PARTLY. ALL RIGHTS IN RESPECT OF PATENTS, DESIGNS AND COPYRIGHT ARE RESERVED.	DRAWN BY: C. FOSTER	DATE: 20-11-92	TITLE DB1 GENERAL ARRANGEMENT	
	D.06-08-07 SO			CHECKED BY: S.J.M.	DATE: 20-11-92		
				APPROVED BY: S.J.M.	DATE: 20-11-92		
		REMOVE ALL BURRS AND SHARP EDGES		SCALE:	SIZE A4	DRG No. DB1	ISSUE D
		MACHINE SYMBOLS THUS					