

SF40 day/night analogue series - UL range

Fixed camera station,
ordinary location



Overview

The Oxalis SF40 is a fixed camera housing for use in onshore, offshore, marine and heavy industrial environments.

The camera housings are designed specifically for the Americas markets or where UL ordinary location standards have been specified. As a result they utilise NPT entries as standard to maximise compatibility with existing installations.

Our camera stations are designed and manufactured for longevity in harsh environments, require minimal maintenance and are fully certified to UL standards.

See separate datasheets for other global certification ranges.

Features

- Electro-polished 316L stainless steel on all welded assemblies
- Camera station window in toughened glass
- Pole or wall mounting options (see separate datasheets)
- NPT entries as standard
- Various camera module options
- Options also available for IP, analogue, hybrid, IP over Coax and direct fibre out* - see specific datasheet
- Supply voltage options (24 VAC)
- -58°F to +158°F* operating temperature
- IP66/67

*Model dependent

Specifications

Features	
Sun shield	Standard stainless steel 316L mirror finish
Integral wiper	Optional (silicone wiper blades that are resistant and do not perish after long exposure to ozone, UV, ice, snow, heat or cold)
Integral demister	Standard
Washer systems	Compatible with Oxalis SW washer tanks (see separate datasheets)
Telemetry receiver	Integral - Pelco D, P standard protocols (others to specification)
Analogue direct fibre out	Optional singlemode 9/125µm or multimode 50/125µm video and data fibre optic transmission, mounted inside the camera station
Type approval	DNVGL-CG-0339, 2016 (copper transmission only)
Ingress protection rating	IP66/67
Electrical	
Supply voltage options	24 VAC
Power consumption	37W maximum (65W with low temperature operation)
Electrical connections	Terminal block for power, data and video specific to camera configuration
Cable entry	2 x ¾" NPT located in rear flange
Mechanical	
Body material	Electro-polished 316L stainless steel on all welded assemblies
Fixings material	A4 stainless steel
Camera station window	Toughened glass
Mounting options	Pole or wall (see separate datasheets)
Operating temperature	From -58°F to +158°F (model dependent)
Weight (lb)	Up to 20lb depending on configuration
Camera options	
1/4" CCD 36x zoom camera	
Image sensor	1/4" EXview HAD CCD (progressive scan)
Resolution	High resolution mode on: 550 TV lines (default)
Lens	36x zoom 3.4-122.4 mm F1.6 to F4.5, horizontal angle of view 57.8° - 1.7°, 12X digital zoom, auto focus, auto Iris
Min. illumination	1/60 s, 1/50 s mode: 1.4 Lux, 1/4 s, 1/3 s mode: 0.1 Lux, 1/4 s, 1/3 s mode & ICR On: 0.01 Lux
S/N ratio	>50dB
Features	ATW, day & night auto/colour / BW (IR-Cut filter removable), camera title ON/OFF
1/3" CMOS varifocal camera	
Image sensor	1/3" 1.3m CMOS
Resolution	Upto 1000 TV lines
Lens	1/3" CS-M 5.0 - 50.0 mm F1.3 - 360 aspherical varifocal, DC auto iris
Min. illumination	Colour : 0.03 Lux (50IRE@F1.2), 0.0003 Lux (1sec F1.2 30IRE) B/W 0.003 Lux (50 IRE@F1.2), 0.000003 Lux (1sec F1.2 30IRE)
S/N ratio	>52dB
Features	WDR 120Db, ATW, SSNRIV, HLC, BLC, SDR, DIS, defog, day & night auto/colour / BW

General arrangement drawing (dimensions in inches and mm)

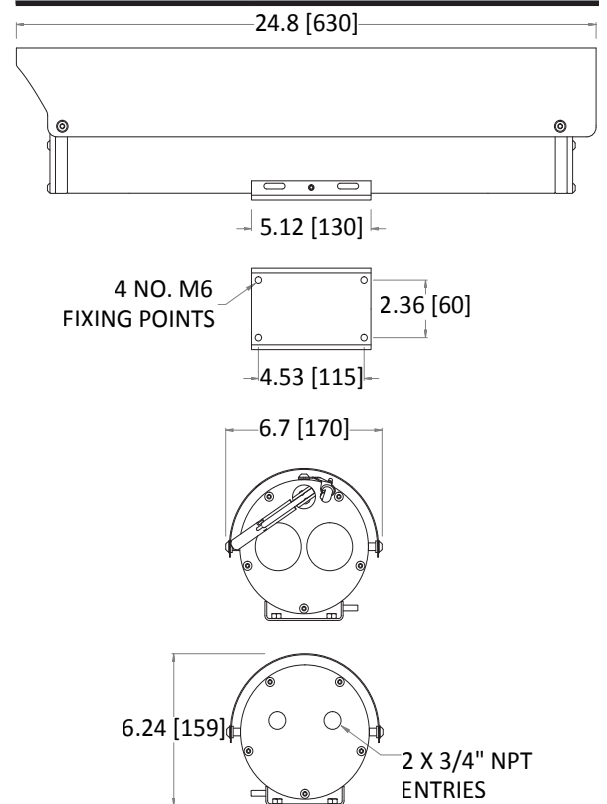

Ordering requirements

The following code is designed to help in selection of the correct unit. Build up the reference number by inserting the code for each component into the appropriate box

